

Installation:

- **This regulator features a vacuum/boost port designed to change fuel pressure at a 1:1 ratio with the amount of boost or vacuum in the intake manifold. Fuel pressure will rise with boost and reduce with vacuum. If unused do not plug the port, leave it open.**
- Disconnect negative battery cable and allow for vehicle to cool.
- Relieve pressure to your fuel system according to your vehicles service manual following all procedures and precautions. Clean up any fuel spillage.
- Make sure to avoid mounting the regulator in a location with excessive heat while keeping the regulator near the fuel rails.
- Attach fuel lines to the supplied -6AN fittings as shown in one of the diagrams shown below. Be sure to use PTFE pipe thread tape on the gauge port fitting.
- Reconnect the battery and turn the ignition to on without starting the car. Check the fuel pressure and check for leaks. If there are no leaks and the pressure does not register on the gauge, cycle the key off, wait and then turn the key back to the on position until fuel pressure registers on the gauge.
- With fuel pressure registering on the gauge check for leaks from all lines and fittings around the regulator.
- Start the engine and adjust the regulator to the desired fuel pressure. Turning the adjustment screw clockwise with an Allen wrench will increase fuel pressure. Once the desired pressure is reached tighten the jam nut.
- Attach the vacuum line if the vehicle has one. If your car is not equipped with a vacuum line, leave the port open to the atmosphere.

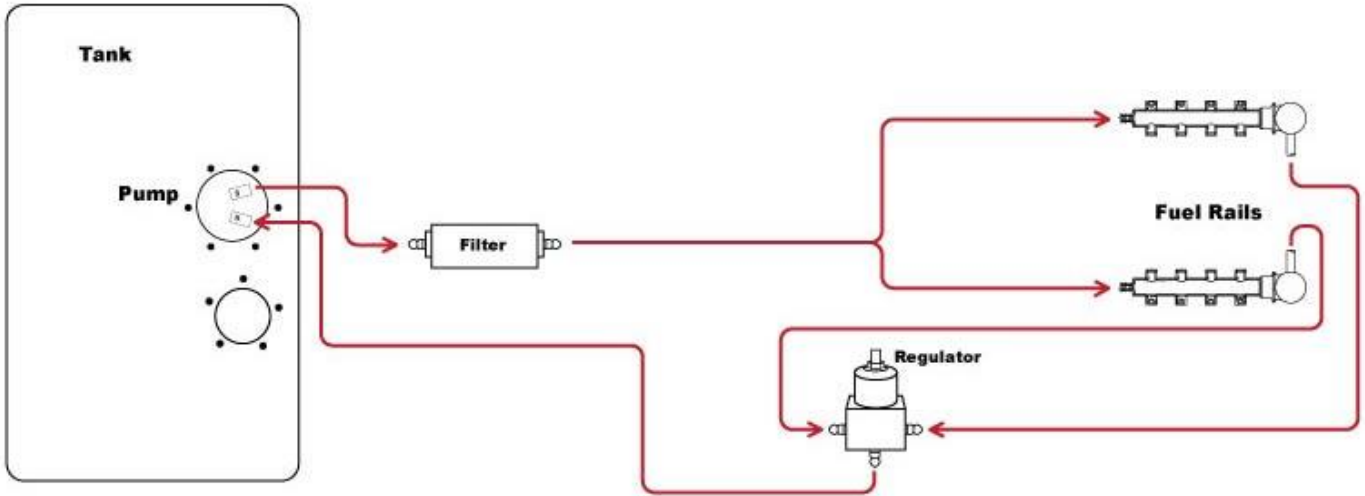



EFI fuel line routing with the regulator after the fuel rails.

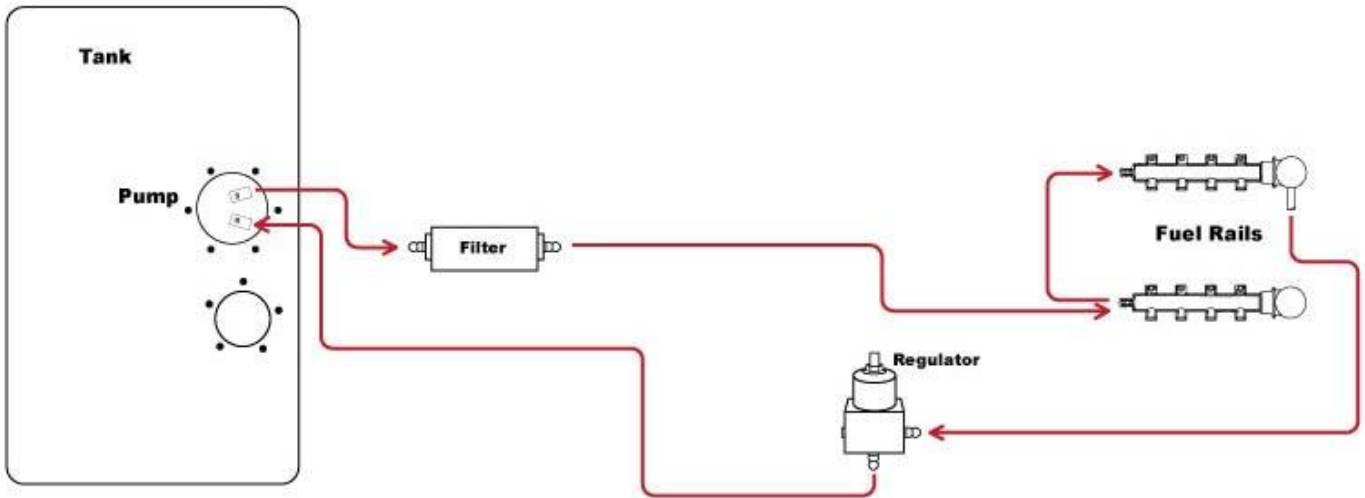

EFI fuel line routing with the regulator after the fuel rails.

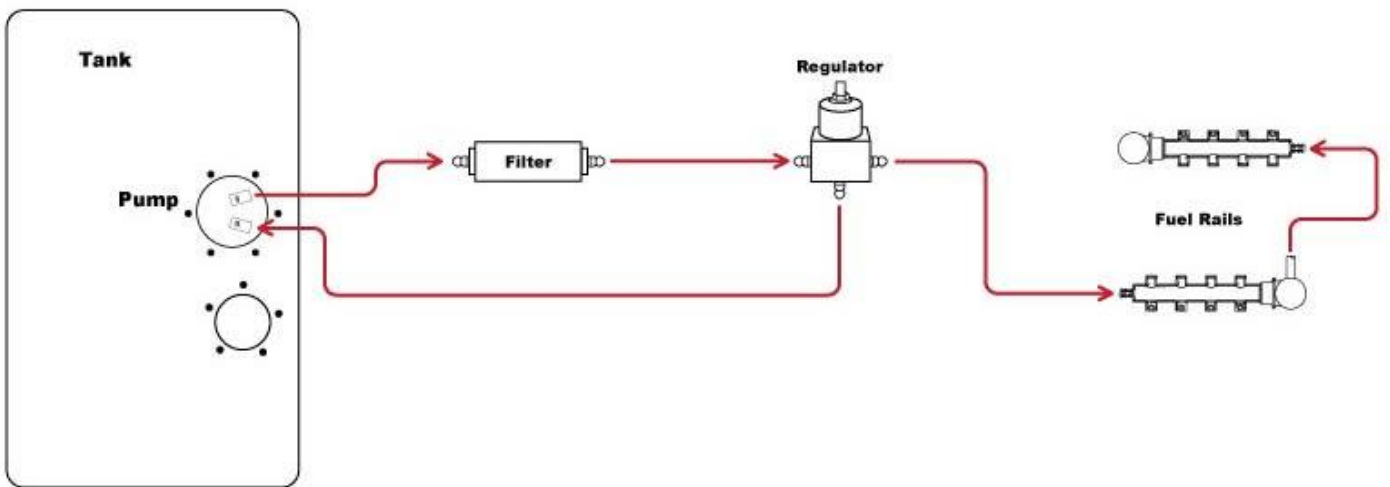

EFI fuel line routing with the regulator before the fuel rails.